

5. Consequences of the nucleonic ec-structure

In the energon hypothesis it is supposed that the nucleons consist of a large number of fast moving ec's of both kinds. The neutrons are thought to contain equal numbers of electrons and positrons, whereas in the protons the number of electrons is one lower than that of the positrons. The nucleons can be considered as the second stage of energon organisation, the first stage being the ec's.

It is obvious that a structure like that, must have its special consequences for the further structuring of matter, and that it has to be very complex. In fact this dynamic structure must be so complex, that all higher forms of matter find its origin in the nucleonic structure. It will be clear that precise description of the inner nucleon will be fundamental impossible, if one realises that even a system of three bodies, moving under the influence of just one kind of force, has proved to be too difficult to make a description of all motions.

Still there are ways to make some approaches to the problem. These ways are equal to those, science often follows in describing the complex phenomena of nature, namely trying to catch the problem in a (very) simplified model. Our manner of simplifying the nucleonic problem includes the next items:

- a/ the spherical nucleons are homogeneously filled with ec's,*
- b/ the spherical ec's move with average velocities at average distances,*
- c/ special consideration of motions and interactions happens in one plane.*

It is thought that the nucleons were formed in a primeval, very dense cloud of ec's. In this cloud, sub-structuring was only possible if the very strong electromagnetic forces between the structures 'in statue nascendi' were neutralised, which means that in these sub-structures all forces must be accompanied by counter forces. Each charge must have a counter charge and each movement of a charge must have its counter movement, even with respect to the relatively weak spin of the charges. In a later stage, development to the uneven number of ec's of the proton happened.

It will be shown that this picture of the nucleons will open the possibility of further investigation. First of all, the ratio between the dimensions of nucleons and ec's will be derived from the simplest combination of an electron and a proton, namely a hydrogen atom in the lowest stage of energy. After that, the average velocity of the nucleonic ec's and the number of it, will be deduced. From the necessary equilibrium between the

inner kinetic and potential energy the dimensions of nucleons and electrons could be deduced and, finally, a new vision on gravitation will be developed, resulting in the deduction of the constant of gravitation.

5.1. The ratio between ec- and nucleon radius

In order to derive the ratio between the dimensions of an ec and a proton, a simplified hydrogen model in a basic state of energy will be used, combined with the simplified model of a proton. In this model, one electron circulates relative slowly around the nucleus with a velocity v_e and at a mean distance r_H . A total number of np ec's whirls around in the nucleus (proton) in a way, that the volume of the proton is filled homogeneously.

According to the principle of mutual neutralisation, the effects of each single charge must be compensated into all directions, except that of the positive surplus one of the proton. Since it is principally impossible to indicate which positive ec is exceeding, one may suppose that this extra charge is distributed over the np ec's of the nucleon. Apart from that, owing to the compensation of charges, the ec's may be considered as being neutral as seen from the outside. Thus, the orbiting electron deals at any moment with a bunch of nuclear ec's, which are homogeneously distributed in a sphere. The charge of each ec may be valued as e/np and may be considered temporarily as place-bound because of its inaccessibility.

The movement of charges may be considered in two ways. In the first place, the electron orbits around a 'rigid' ec-structure of the nucleon over an angle of $v_e \cdot dt / r_H$ radians. Secondly, the bunch of rigid partial charges of the nucleon rotates over the same angle in the same period of time into an opposite direction, with respect to the ec in its orbit. Accepting this, we see that the ec's may compensate the effects of relative movement, but not the rotation around the axes with respect to the orbiting electron. Thus, each ec rotates with respect to the orbiting ec, but regarding the

Figure 31 a

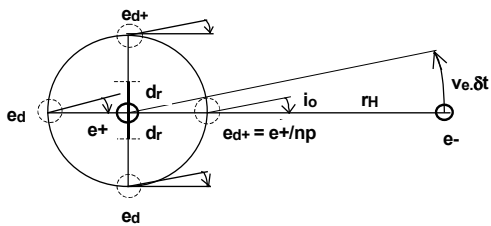
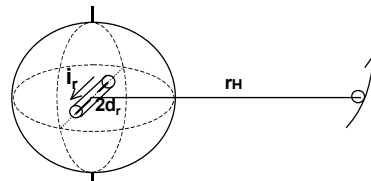

Figure 31 b



total charge it may be seen as one rotating ec. In **figure 31 a** the described situation is pictured. If $i_0 \cdot r / \pi \cdot r = i_0 / \pi$ means the transport of charge along the equator of the surplus ec, relative to half of its circumference, the mean transport along half of its surface is:

$$(i_0 / \pi) \times (2 / \pi) = \frac{1}{2} \cdot (2 / \pi)^2 \times i_0.$$

Because of the inaccessibility of the surplus charge, the partitioned charges $e / n p$ can be imagined as being gathered along a short line through the centre and in the plane of orbit, perpendicular to r_H . This line has the length of two times the mean height of the hemisphere of the nucleon: $(2 / \pi)^2 \cdot r_p' \times 2 = 2 \cdot d_r$,

where r_p' is the radius of the nucleon (see **figure 31 b**). The gathered charge $+ e$, rotating according fig. 31a, and length $2 \cdot d_r$ can now be considered as current and length, $\frac{1}{2} \cdot (2 / \pi)^2 \cdot i_0 \times (2 / \pi)^2 \cdot r_p' \times 2$, of the conductor in the equation of Biot-Savart, describing the strength of the magnetic field at a distance r_H :

$$H = \frac{i \cdot \delta l}{10 \cdot r^2} \cdot (\sin \alpha) \text{ oersted} = 10^{-3} \times 79.577 \times \frac{(2 / \pi)^4 \times i_0 \times r_p'}{r_H^2} \text{ A.m}^{-1}$$

$$H = 0.013071 \times \frac{i_0 \times r_p'}{r_H^2} \text{ A.m}^{-1}$$

The transport of charge, as a result of the rotation of the surplus ec with respect to the orbiting ec, must be equal to the transport of charge, as a result of the transversal displacement of the orbiting ec with respect to the rigid nucleon structure.

The transport of charge by the orbiting electron, being in its lowest stage of energy, can be calculated from:

$$r_H = \frac{\epsilon_0 \cdot h^2 \cdot n^2}{\pi \cdot m_e \cdot e^2} \text{ m} ; v_e = \frac{e^2}{2 \cdot \epsilon_0 \cdot h} \text{ m.s}^{-1}, \text{ involving the quantum number } n=1.$$

For reasons of convenience, the physical constants that are used in the calculations, are given below (see Bulletin No.11, ICSU CODATA Central Office, Frankf./Main).

Electron Rest Mass	Permittivity of Vacuum
$m_e = 0.9109534 \times 10^{-30} \text{ kg}$	$\epsilon_0 = 8.8541878 \times 10^{-12} \text{ C.V}^{-1} \cdot \text{m}^{-1}$
Neutron Rest Mass	Planck Constant
$m_n = 1.6749543 \times 10^{-27} \text{ kg}$	$h = 6.6261764 \times 10^{-34} \text{ kg.m}^2 \cdot \text{s}^{-1}$
Proton Rest Mass	Gravitational Constant
$m_p = 1.6726485 \times 10^{-27} \text{ kg}$	$G = 6.6720 \times 10^{-11} \text{ N.m}^2 \cdot \text{kg}^{-2}$
Elementary Charge	Speed of Light in Vacuum
$e = 1.6021892 \times 10^{-19} \text{ C}$	$C = 2.997925 \times 10^8 \text{ m.s}^{-1}$
Electron Magnetic Moment	Permeability of Vacuum
$\mu_e = 9.2848324 \times 10^{-24} \text{ J.T}^{-1}$	$\mu_0 = 4 \cdot \pi \cdot 10^{-7} \text{ H.m}^{-1}$

Substituting the relevant constants into the formulas given before, the radius r_H and the velocity v_e are respectively:

$$r_H = 5.29176 \times 10^{-11} \text{ m} \text{ and } v_e = 2.18769 \times 10^6 \text{ m.s}^{-1}.$$

Hence, the orbiting frequency is:

$$\omega = v_e / (2\pi \cdot r_H) = 6.57969 \times 10^{15} \text{ s}^{-1}.$$

This matches a transport of charge:

$$i_o = \omega \cdot e = 6.57969 \times 10^{15} \times 1.6021892 \times 10^{-19} = 1.05419 \times 10^{-3} \text{ e.s}^{-1} \text{ (A)}.$$

The strength of the magnetic field at the orbiting electron is found to be:

$$\begin{aligned} H &= 0.013071 \times 1.05419 \times 10^{-3} \times r_p' / (5.29176 \times 10^{-11})^2 \\ &= 4.9207 \times 10^{15} \times r_p' \text{ A.m}^{-1}. \end{aligned}$$

The magnetic force between proton and electron amounts to:

$$f_\mu = \frac{e^2}{4\pi \cdot \epsilon_0 \cdot r_H^2} \times \left\{ \frac{1}{\sqrt{1 - (v_e/c)^2}} - 1 \right\} = 2.1937 \times 10^{-12} \text{ N}$$

The magnetic moment of an electron is known and can be written as:

$$\mu_e = (2 \cdot f_\mu \cdot r_e) / \mu_0 = 9.2848324 \times 10^{-24} \text{ kg.m}^3 \cdot \text{s}^{-2} \cdot \text{H} \text{ or } \text{J.T}^{-1},$$

in which $r_e = ec$ -radius, hence:

$$r_e = \mu_0 \cdot \mu_e / 2f_\mu = 4\pi \cdot 10^{-7} \cdot \mu_e \cdot H / 2f_\mu = 0.013086 \cdot r_p', \text{ or}$$

$$\frac{r_e}{r_p'} = \frac{2.05319 \times 10^{-2} \cdot \mu_0 \cdot \mu_e \cdot m_e \cdot e^3}{\left\{ \sqrt{1 + (v_e/c)^2} - 1 \right\} \cdot \epsilon_0 \cdot h^3} = 0.013086 = \frac{r_e}{r_n}$$

Note that the factor $g/2 \times 0.01307 = 0.013086$, where $g/2 = \mu_e / \mu_S = 1.001166$. Thus the factor g has been included with this calculation (see § 2.3 and Chapter 13.0).

The two radii, r_p' and r_n , are equalised in this equation. To make this more understandable, it is necessary to refer to chapter 6 about gravity. According to the gravity hypothesis, positive ec 's do not take the same volume in nucleons as negative ec 's do: the positive volume is thought to be a little smaller because the negative ec 's take the outside curve at passage of a positive ec . The calculation of the ratio between r_e and a nucleon is only applicable to the volume of positive ec 's in protons, but the high degree of agreement between the calculated and the real value of the constant of gravity may indicate that this positive volume is equal to the total volume of neutrons. Indeed, it can be reasoned that the radius of a proton is a little larger than the radius of a neutron (0.48%, see § 5.4.2).

The ratio between r_e and r_n will appear indispensable for some of the following deductions.

5.2. The average relative velocity of neutron charges

First approach.

In the hypothetical primeval *ec*-plasma, immediately following the 'Big Bang', only three particles could have been operative: the two elementary charges and the photons, being the intermediates for interaction (seeming particles). According to the energon hypothesis the now-a-days nucleons are the shivers of an exploding universe. This means that inside the nucleons still the same processes between the *ec*'s are acting, but now forcing the structures into a balance between the centrifugal momentum of the *ec*'s and the centripetal momentum of photons.

Momentum is expressed as the product of mass and velocity. The *ec*-mass, however, is not considered to be an internal property of the *ec*'s, but is rather connected with the production and action of the field of power particles (*pp*'s). When we are speaking about the balance of the momentums of *ec*-mass and photon-mass, we are speaking in fact about the same defining system of mass. This means that the average, relative *ec*-velocity (V_N) inside the neutrons depends on the interaction of photons and *ec*'s at the relative velocity of light (c). The photons are considered to be the combined energetic action of multiple *pp*'s.

A simplified model in **figure 32** shows an *ec*, moving with velocity V_N along the Z-axis of a system. Photons (or *pp*'s) influence the *ec*-momentum. Therefore they point to the *ec*-centre M and come from all directions. They can be divided into two categories: those with a potential momentum perpendicular to the *ec*-momentum (averagely moving within the XY -plane through M) and those with a potential momentum having a velocity component parallel to the Z-axis: $C_p' = c \cdot \sin \alpha$

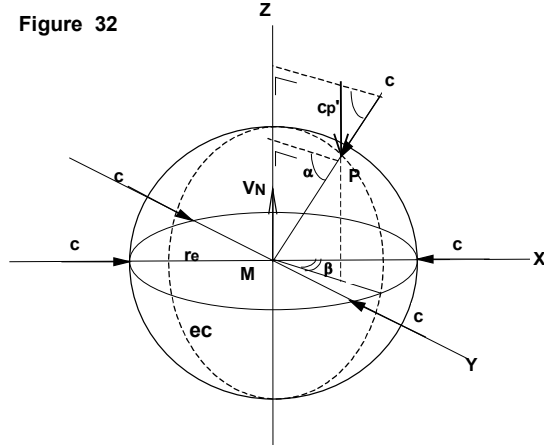

In the V_N -pointed hemisphere, the average of all C_p' -values of the second category is:

$$C_p = \left(\frac{2}{\pi}\right)^2 \cdot c \cdot \int_0^{\pi/2} \left(\int_0^{\pi/2} \sin \alpha \cdot d\alpha \right) \cdot \sin \beta \cdot d\beta = \left(\frac{2}{\pi}\right)^2 \cdot c$$

which has a point of application at a distance $(2/\pi)^2 \cdot r_e$ from M on the Z-axis. The photons of the first category do not possess points of application with a r_e -value along the Z-axis. Regarded per period of time, momentum gets the dimensions of force: $M.L.T^{-1}.T^{-1} = M.L.T^{-2}$.

The total of ec -momentum pointing into all directions, per units of time and volume, may be indicated by the dimensions $(M.L.T^{-2})^3.L^{-3}$.

About the balance of ec 's and photons inside neutrons, now may be said:

The total of centrifugal ec -momentum per unit of time per neutron volume is equal to the total of centripetal photon momentum, while the total masses of ec 's and photons are equal as well .

This principle may be presented in a formula as follows:

$$\frac{(m_x \cdot V_N / t_x)^3}{4\pi \cdot r_n^3 / 3} = \frac{(m_x \cdot c / t_x)^2}{4\pi \cdot r_n^2 / 3} \times \frac{(m_x \cdot C_p / t_x)}{r_n'}$$

In the last term, the radius of the neutron, r_n has to be corrected by the average point of application of C_p :

$$r_n' = r_n - (2/\pi)^2 \cdot r_e, \text{ thus } (r_n'/r_n) = 1 - (2/\pi)^2 \cdot (r_e/r_n), \text{ or } (r_n'/r_n) \approx 1 + (2/\pi)^2 \cdot (r_e/r_n),$$

In the above formula, mass and time can be extinguished:

$$(V_N/r_n)^3 = (c/r_n)^2 \cdot (C_p/r_n'), \text{ or, } (V_N/c)^3 = (C_p/c) \cdot (r_n'/r_n), \text{ thus}$$

$$\frac{V_N}{c} = \sqrt[3]{\frac{C_p}{c} \cdot \frac{r_n}{r_n'}} , \text{ thus } \frac{V_N}{c} = \sqrt[3]{\left(\frac{2}{\pi}\right)^2 \cdot \left\{1 + \left(\frac{2}{\pi}\right)^2 \cdot \frac{r_e}{r_n}\right\}}$$

In the preceding paragraph it was found that $r_e/r_n = 0.013086$, hence :

$$\mathbf{V_N \approx 0.74134 \cdot c}$$

Note that this value is only 5‰ lower than the ultimate velocity for harmonious, transversal interaction (0.745.c), as derived in paragraph 3.4.

Second approach.

The second approaches to V_N and nn in the next paragraphs have a link to § 5.4 about the dimensions of r_n and r_e .

The value of V_N can be derived using an other way, namely a length-time dialogram as shown in **figure 33**, where $r_n = 1$ and $c = 1$. In that figure a situation is considered at

ad. b. The neutron radius has also to be corrected for the eccentricity of the electric ec-point e_{ex} (§ 3.5.3), probably in relation with the ec-pulsation (§ 7.1) with a frequency $7.9 \times 10^{24} \text{ s}^{-1}$. That causes an amount of pulsations per Δt -period of $7.9 \times 10^{24} \times r_p \cdot \sqrt{2} / c \approx 19$. A slight difference in the nucleon radius can cause the difference between an *in-phase* and a *counter-phase* interaction, the *normal* and the *reduced* one, making one e_{ex} -step with a length-variation of $e_{ex} \approx 0.14 \cdot r_e \approx 0.0018 \cdot r_n$

The reduced correction is thought to be e_{ex} and the normal correction $2e_{ex}$. It is strikingly to find that in neutrons the reduced correction has to be applied (e_{ex}) and in protons the normal correction ($2e_{ex}$, see also § 7.3.1).

According to these presuppositions, the correcting factor for neutrons becomes:

$$r_n'/r_n = \{r_n - (2/\pi)^2 \cdot a_m - e_{ex}\} / r_n = \mathbf{0.94505},$$

$$\text{where } a_m = 0.131029 \cdot r_n \text{ and } e_{ex} = 1.8402 \cdot 10^{-3} r_n \text{ (see § 3.5.3; § 5.4).}$$

From the periods of time and length, in this situation, can be remarked:

$$\sqrt{L^2 + t_v^2} = \sqrt{2} ; L/t_v = c + V = 1.5, \text{ thus } \sqrt{\{(3/2) \cdot t_v\}^2 + t_v^2} = \sqrt{2}, \text{ thus:}$$

$$t_v = 0.7844645 \text{ rest-units, where } t_v = R'Z' = OS \text{ and } L = OZ'.$$

Because velocity c , being the average of $(c-V)$ and $(c+V)$, divides line OS into two equal parts in point O' , each of these parts are also equal to line $t_v/2$. Like all distances, expressed in r_n and c (the whole figure), OS must be corrected by the factor 0.94505:

$$\mathbf{0.94505 \times OS = 0.94505 \times 0.7844645 = 0.74136 \text{ rest-units.}}$$

The dynamic units must be handled like real units.

Each half of the corrected OS refers to the velocity of the moving *ec*-systems: the centripetal velocity with the value $-0.74136/2$, reducing the $(c+V)$ -*pp*'s to velocity c , and the centrifugal speed $+0.74136/2$, accelerating the $(c-V)$ -*pp*'s to velocity c .

Thus, the average mutual velocity between the two *ec*-systems amounts to:

$$\mathbf{V_N = \{[r_n - (2/\pi)^2 \cdot a_m - e_{ex}] / r_n\} \times 0.7844645 \times c = 0.74136 \cdot c}$$

According to the preceding presupposition, the average relative velocity between *ec*'s in protons must be:

$$\mathbf{V_P = \{[r_p - (2/\pi)^2 \cdot a_{mp} - 2e_{ex}] / r_p\} \times 0.7844645 \times c = 0.73991 \cdot c}$$

$$\text{in which } a_{mp} = 0.1311 \cdot r_p \text{ and } e_{ex} = 1.8311 \cdot 10^{-3} \cdot r_p.$$

In § 5.5 an equal value of V_p is deduced, using a different approach. This supports the idea of two different types of *ec*-interaction in protons and neutrons.

5.3. The amount of neutron charges

First approach.

In this consideration, the compensation principle for charges is used to explain some aspects of the existence of neutrons. To that purpose, it is necessary to start the viewing with 12 charges along one line through the middle of the structure. This includes the ec's of both kinds, moving oppositely along the three axes of the system.

If compensation should be operative only for these three main directions, a cube shaped by $12^3 = 1728$ ec's would be sufficient. However, full compensation must be attained into all directions. Therefore, it is necessary to shift to a spherical shaped system of ec's, possessing the same capacity as the cube did.

From **figure 35** may be seen that the edge of the cube (r_k) and the radius of the sphere (r_n) can be connected by the equation:

$$r_k^3 = (4/3) \cdot \pi \cdot r_n^3, \text{ or } r_k = 1.61199 \cdot r_n.$$

Like in the preceding paragraph, also in this case a correction for the size (r_e) of the ec's must be made.

In a spherical structure the radius r_n comprises only one ec, whereas in a cube the edges r_k have two of it. This difference causes a slight shift in the above ratio:

$$r_k' + 2 \cdot r_e = 1.61199 \cdot r_n + r_e, \text{ hence } r_k' = 1.61199 \cdot r_n - r_e$$

In a previous paragraph (5.1) the ratio r_n/r_e was determined:

$$r_n/r_e = 1/0.013086 = 76.4175, \text{ thus}$$

$$r_k' = 122.1844 \cdot r_e, \text{ and } 2 \cdot r_n/r_k' = 1.250855.$$

After this rectification, the newly derived cube with the edge r_k' must be thought to move around three axes in order to get a correct compensation, so that this edge will be averaged over all directions, up to the average length r_k'' , from which may be written:

$$\frac{2 \cdot r_n}{r_k''} = \sqrt[3]{\frac{2 \cdot r_n}{r_k'}} = 1.077463$$

The original number of 12^3 ec's has to be multiplied by this factor in order to gain the right compensation power in the spherical ec-cluster. If this new number is indicated by nn , the above reasoning can be comprised in one formula:

Figure 35

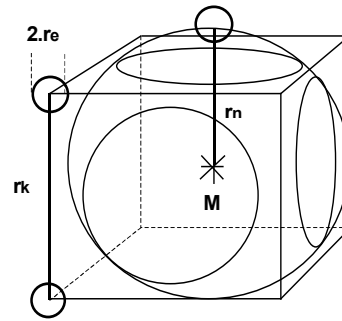

$$\begin{aligned}
 nn &= 12^3 \cdot \sqrt[3]{\frac{2 \cdot r_n}{r_n \cdot \sqrt[3]{4\pi/3} - r_e}} = 12^3 \cdot \sqrt[3]{\frac{\text{nucleon diameter}}{\sqrt[3]{\text{nucleonic capacity}} - \text{ec radius}}} \\
 &= 12^3 \cdot \sqrt[3]{\frac{2}{\sqrt[3]{4\pi/3} - r_e / r_n}} = \mathbf{1861.86}
 \end{aligned}$$

Second approach.

In a second approach following a different way, an equal value of nn is obtained by using the value of the average relative ec -velocity in neutrons (V_N), together with the known rest values of the masses of ec 's and nucleons (m_e , m_n and m_p). This provides an indication for the correctness of the V_N - and r_e/r_n -calculations.

The gravitational force between two neutrons may be described by:

$$\mathbf{f_G = G \cdot m_n^2 / R^2}$$

G = gravitational constant, R = distance between the neutrons,
 m_n = rest-mass of a neutron.

If G is considered to be the result of electrical interaction (see treatment of gravitation), it also implies:

$$\mathbf{f_G = (x \cdot e)^2 \cdot k / (R^2 \cdot K_r)}$$

K_r = ratio between electrical- and gravitational force,

x = number of gravity active charges per neutron, $k = (4 \cdot \pi \cdot \epsilon_0)^{-1}$.

Paul Dirac used the conception 'force constant', being the ratio, void of dimensions, between the electrical- and gravitational force, operative between proton and electron. It should be noted that in this concept both forces are considered to work between the particles in a fixed position. According to this concept, the gravitational force between electron and proton may be described as:

$$\mathbf{f_g = G \cdot m_e \cdot m_p / R^2}, \text{ and the electrical force as : } \mathbf{f_e = e^2 \cdot k / R^2}.$$

Hence, the force constant measures:

$$\mathbf{K = f_e / f_g = e^2 \cdot k / (G \cdot m_e \cdot m_p)}$$

In the context of our analysis this force constant does not exist in 'sensu stricto' for single particles. In fact, the force constant in the sense of Dirac is not measurable at all, because, in that case, one has to accept large numbers of fixed equal charges within small volumes:

$$\mathbf{K = (ye)^2 \cdot k / (G \cdot ym_e \cdot ym_p)}.$$

This difficulty is much less prominent in the case of moving ec 's in clusters of neutrons. In the formulas relevant to this situation (see above), the use of the force constant K_r seems more justified. The elimination of f_g from these equations leads to an equation, describing the square of active charges per neutron:

$$x^2 = G.m_n^2.K_r / k.e^2,$$

in which K_r may be considered as K , rectified for charge velocities.

By taking $K_r = p.K$, the equation for x^2 may be presented as:

$$x^2 = \{(G.m_n^2) / k.e^2\} \times \{e^2.k / (G.m_e.m_p)\} \times p, \text{ or}$$

$$x^2 = (m_n^2.p) / (m_e.m_p)$$

Opposite charges, thought to be packed into one cluster, need to have a relative speed.

According to the reasoning in paragraph 5.2 this speed must be $0.7413.c$, or, with respect to the whole structure $V_N/2 = 0.3705.c$.

This means that the average velocity of the neutronic ec 's into one direction must be:

$$V_N = (2/\pi)^2.V_N/2,$$

which leads to the following *factor of communication* with an outside ec (p) or with ec 's in another nucleon (p^2), comparable with the factor of *Lorentz-Fitzgerald* :

$$\sqrt{\left(\frac{c}{c+V_N}\right) \times \left(\frac{c}{c-V_N}\right)} = \sqrt{\frac{1}{1-(V_N/c)^2}} \approx \sqrt{1+(V_N/c)^2}, \text{ thus}$$

$$p = \sqrt{1 + \left\{ \left(\frac{2}{\pi}\right)^2 \times \frac{V_N}{2c} \right\}^2} = 1.01122, \text{ hence}$$

$$x^2 = nn = \frac{m_n^2}{m_e.m_p} \cdot \sqrt{1 + \left\{ \left(\frac{2}{\pi}\right)^2 \times \frac{V_N}{2c} \right\}^2} = \mathbf{1861.88}$$

$$\text{thus } K_r = 1.01122 \times K = \mathbf{2.2948.10^{39}}.$$

The number, found in this reasoning, is very close to the number of ec 's per neutron, found in the first approach (1861.86).

In chapter 6, treating gravitation, it will be shown that the real number of ec 's per neutron (nn) is equal to the square of the gravity active ec 's (x).

Of course, the real number must be an integer, thus

$$\mathbf{nn = 1862},$$

but the fact that, two times, a number has been found that is just a little smaller, must have a meaning. It may be that the smaller number points to the fact that neutrons are slightly unstable, because the number of 1862 ec 's is just a little too large for a harmonious, stable interaction between those ec 's.

Possibly, an asymmetry of ec -conjunctions in nucleons can be responsible for a seemingly disappearance of a (small) part of a kind of charge, making the total of participating charges is found to be lower than expected (see also § 6.3.2).

5.4. The dimensions of nucleons and ec's

In paragraph 3.5.2 the equilibrium of the potential and kinetic energy in a stable twin-structure of ec's has been investigated. A similar situation can be met in the much more complicated ec-structures of nucleons.

It is beyond doubt that inside a huge cluster of equal numbers of positive and negative charges the attracting forces are dominating if the positive charges are alternated by the negative ones. An equilibrium can only be achieved if the charges are very fast moving. In the preceding paragraphs it has been shown that the total number of the composing ec's in a neutron must be 1862 (931 positive and 931 negative ec's), and that the average relative velocity of these ec's may be put on $0.7413.c$, or $2.22236 \cdot 10^8 \text{ m.s}^{-1}$. The links, in this complicated wrapped chain of ec's, are formed by the attracting opposite neighbour ec's. If the *smallest average distance between the neutron ec's is put on a_m* , then the potential energy between two attracting neighbour ec's can be calculated: $-PE_n = e^2 / (4\pi \epsilon_0 \cdot a_m)$.

Selecting an ec-link in the centre of the neutron cluster, one can imagine to divide the rest of the ec's into four parts of 465 ec's, namely two pairs of clusters with opposite charges, circulating into opposite directions with an average relative velocity $(2/\pi)^2 \cdot V_N$, perpendicular to the radius of the structure. The link in the centre must be strong enough to provide a counterweight for the centrifugal force on each part. This image can be applied to the involved energies:

$$\frac{e^2}{4 \cdot \pi \cdot \epsilon_0 \cdot a_m} = \frac{nn \cdot m_e}{4} \cdot \left\{ \left(\frac{2}{\pi} \right)^2 \cdot V_N \right\}^2$$

The single unknown in this equation is a_m , for which can be written:

$$a_m = \frac{e^2}{nn \cdot \pi \cdot \epsilon_0 \cdot m_e \cdot \left\{ \left(2 / \pi \right)^2 \cdot V_N \right\}^2}$$

This ec-distance in a neutron is:

$$a_m = 6.7066 \times 10^{-17} \text{ m,}$$

and because:

$$a_m = \frac{r_n}{\sqrt[3]{(3/4) \cdot (nn / \pi)}} = 0.13103 \cdot r_n$$

the idealised neutron radius becomes:

$$r_n = 5.1184 \times 10^{-16} \text{ m.}$$

From $r_e = 0.013086 \times r_n$ the average radius

of an ec can be derived:

$$r_e = 6.6979 \times 10^{-18} \text{ m.}$$

5.4.1. Balance and mutation of energy at the transformation of neutrons into protons

The neutron decay.

Neutrons are slightly unstable. Outside nuclei a neutron exists averagely about 15 minutes, then it decays into a proton, an electron and an anti electron-neutrino ($\bar{\nu}$) according to: $n \rightarrow p^+ + e^- + \bar{\nu}$

In the context of our neutron model, this event has the following meaning.

The instability of a neutron, probably the result of a small excess of negative charge motion, causes the expulsion of an electron and of an electron-positron twin structure (poël). The energy of this expulsion is thought to originate from the primeval energy, enclosed in each pair of opposite ec's, being too close together inside the neutron structure. By occupying the natural format of the poël (diameter r_m), the ec-pair yields the energy E_β , which is portioned between the liberated electron and the created proton. The portioning key is thought to be:

$$\frac{E_k}{-E_a} = \frac{2 \cdot r_n}{2 \cdot a_m \cdot k_{am}} = 7.8468$$

E_k = kinetic energy of the expelled electron

$-E_a$ = the energy, absorbed by the proton

$2r_n/(2a_m \cdot k_{am})$ = ratio between the neutron diameter and the average shortest distance between two equal charged ec's at most efficient spatial packing

($k_{am} = 0.97261$, see § 5.4.2).

The total value of this altered energy must be:

$$E_p = 2 \cdot m_n \cdot c^2 / nn = 1.61694 \times 10^{-13} \text{ J} = 1.009 \text{ MeV.}$$

With the aid of the above mentioned portioning key the diverse energies may be calculated:

$$-E_a = 1.83 \times 10^{-14} \text{ J} = 0.114 \text{ MeV}$$

$$E_k = 1.434 \times 10^{-13} \text{ J} = 0.895 \text{ MeV} \quad (\sim \text{ec-velocity } 0.891 \times c)$$

If the total energy of a nucleon is considered, one may say:

$$E_p = m_p \cdot c^2 = m_n \cdot c^2 - 3 \cdot m_n \cdot c^2 / nn - E_a = 1.5033 \times 10^{-10} \text{ J} = 938 \text{ MeV}$$

$$\text{thus } m_n \cdot c^2 = 1.5054 \times 10^{-10} \text{ J} = 939.37 \text{ MeV}$$

$$-3 \cdot m_n \cdot c^2 / nn = -2.4254 \times 10^{-13} \text{ J} = -1.51 \text{ MeV}$$

$$-E_a = 1.83 \times 10^{-14} \text{ J} = 0.11 \text{ MeV}$$

$$m_p \cdot c^2 = 1.5032 \times 10^{-10} \text{ J} = 938 \text{ MeV} \quad +$$

The balance of energy.

It is clear that the ec's inside the nucleons must show a lower mass than free ec's in a rest situation:

$$m_n - m_p = 2.3058 \times 10^{-30} \text{ kg, whereas}$$

$$3 m_e = 2.73286 \times 10^{-30} \text{ kg,}$$

With the next reasoning this difficulty could be avoided. It seems that some of the ec-mass, concerning the decay of neutrons into protons, is still present in the diverse structures in a hidden form.

According to the equation of energy balance in neutrons, the kinetic energy of the hidden mass may be described by:

$$E_d = (1/4) \cdot (n \cdot m_e - m_n) \cdot \left\{ \frac{2}{\pi} \cdot V_N \right\}^2 = 4.30787 \times 10^{-14} \text{ J}$$

The liberated energy at neutron decay may be put on:

$$E_e' = \{ (n \cdot m_e - m_n) - (n_p \cdot m_e - m_p) \} \cdot c^2 = (m_p + 3 \cdot m_e - m_n) \cdot c^2 = 3.83822 \times 10^{-14} \text{ J}$$

The hidden energy of a poël may be deduced to:

$$E_v = e^2 / (4\pi\epsilon_0 \cdot r_m') = 4.26517 \times 10^{-14} \text{ J}$$

It is striking to find that these three quanta of energy are equal, if corrected according to small factors, the similarity of which is evident:

$$E_d \cdot (99/100) = E_e' \cdot (10/9) = E_v \cdot (9999/10000) = 4.2648 \times 10^{-14} \text{ J} = 0.266 \text{ MeV}$$

As has been shown in paragraph 3.5.2, the factor belonging to E_v describes the conversion of a system of point-like charges into that of natural charges (factor 1/1.0001). Because of the similarity of the factors, it seems logic that the same mechanism may be attributed to the other two factors.

Therefore, the following acceptation of the factors seems to be likely:

$$\frac{99}{100} = \frac{(a_m + r_e) \cdot (a_m - r_e)}{a_m^2}, \quad \frac{10}{9} = \frac{a_m}{a_m - r_e}, \quad \frac{9999}{10000} = \frac{r_m' - (2/3) \cdot e_{ex}}{r_m'}$$

Thus, these factors seem to be defined by the ratio of the dimensions of charges and the distances between.

The general law of energy conservation seems to be applicable too for this kind of energy. The first form (E_d) is connected to the situation before decay, the second (E_e') links neutron and proton by three migrating ec's, and the third (E_v) describes the definite situation inside the poël. Some supplementing data are given below:

$$m_e = \text{rest mass of ec's} = 0.9109534 \times 10^{-30} \text{ kg}$$

$$m_n = \text{rest mass of neutrons} = 1.6749543 \times 10^{-27} \text{ kg}$$

$$m_p = \text{rest mass of protons} = 1.6726485 \times 10^{-27} \text{ kg}$$

nn = number of neutron ec's = 1862 (931 e^+ and 931 e^-)

np = number of proton ec's = 1859 (930 e^+ and 929 e^-)

c = velocity of light = 2.997925×10^8 m.s⁻¹

r_e = ec-radius = 6.6979×10^{-18} m

r_n = neutron radius (idealised) = 5.1184×10^{-16} m, derived from:

$$r_n = \left(\frac{\pi}{4}\right)^2 \times \sqrt[3]{\frac{3}{4} \cdot \left(\frac{\pi}{nn}\right)^2} \times \frac{e^2}{\epsilon_0 \cdot m_e \cdot V_N^2}$$

r_m = poël radius (natural ec's) = 5.40966×10^{-15} m = 807.6651. r_e

r_m' = poël radius (point-like ec's) = 5.40912×10^{-15} m = 807.5845. r_e

$$r_m/r_m' = r_m/(r_m' - 2e_{ex}/3); \quad (e_{ex} = 0,1406 \cdot r_e)$$

5.4.2 The radius of a proton

The idealised proton radius.

From the equation of energy balance (see § 5.4), where $m_e = 0.91095 \times 10^{-30}$ kg and $V_N = 0.7413 \cdot c$, the value of the average distance between two neighbour ec's in a proton can be found, because the change of energy has far more influence than the change of ec-number:

$$\frac{e^2}{4 \cdot \pi \cdot \epsilon_0 \cdot a_m} = \frac{nn \cdot m_e}{4} \times \left\{ \left(\frac{2}{\pi}\right)^2 \cdot V_N \right\}^2 = -PE_n = 3.44005 \times 10^{-12} \text{ J}$$

$$a_{mp} = \frac{e^2}{4 \cdot \pi \cdot \epsilon_0 \cdot (-PE_n + E_a)} = \frac{2.30711 \times 10^{-28}}{(344.005 - 1.83) \times 10^{-14}}$$

thus $a_{mp} = 6.7425 \times 10^{-17}$ m = 10.0666. r_e

E_a is that part of the energy of neutron decay, which is absorbed by the proton, and is equivalent to 1.83×10^{-14} J (see § 5.4.1).

The radius of the idealised proton may be calculated according to:

$$r_p = a_{mp} \cdot \sqrt[3]{\frac{3}{4} \cdot \frac{np}{\pi}}$$

where the number of proton-ec's: $np = 1862 - 3 = 1859$, thus:

$$r_p = 76.786 \cdot r_e = 5.1430 \times 10^{-16} \text{ m} = 0.5143 \text{ fm (fermi)}$$

The radius of a neutron was found to be 5.1184×10^{-16} m, hence the proton radius exceeds that of neutrons with 0.48 %.

The actual proton radius and the ec-densities.

The model of the nucleons was simplified by the assumption that the composing ec's are homogeneously dispersed over the volume. However, experiments with electron-proton scattering indicated that the positive charge of the proton is not homogeneously divided over the proton volume. The actual radius of a proton was found to be between 0.80 and 0.88 fm.

The diverse qualities of the idealised proton, including its radius, are thought to possess the average values. It is supposed that the average value of the proton radius is equal to the mean height of its central section, seen from the central line, thus:

$$r_p = (2/\pi) \cdot R_p, \text{ or the actual proton radius must be:}$$

$$R_p = (\pi/2) \times r_p = 0.81 \times 10^{-15} \text{ m.}$$

An elliptic function seems most obvious in the relation between the ec-density in a small part of the proton volume, and its distance to the proton centre. Like the more special circular relation, the elliptic relation leads namely to a density that will vary smoothly from a flat course near the centre to a sheer decline at the periphery.

With the presumption of an elliptic relation between the local ec-density and the radius, one can handle the problem by considering the cross-section area through the centre.

The values in the elliptic function, could be derived according to:

$$x^2/a^2 + y^2/b^2 = 1.$$

A complication is the fact that the density along the radius in the cross-section must be seen in relation to the capacities of two spheres: one with the average radius r_p and the other with the maximum radius R_p (see **figure 36**).

It can be proved that the average value of ec-density along r is about $\pi/4$ times the maximum value (see page 142/143), thus:

$$D_{\max} \approx 4/\pi \times D_p.$$

Now it is possible to give the equation the following shape, if r_p and D_p are respectively the units of proton-radius and ec-density, in which r_x and D_y have to be expressed:

$$\left\{ \frac{r_x \cdot k_{am}}{(\pi/2) \cdot r_p} \right\}^2 + \left\{ \frac{D_y}{(4/\pi) \cdot D_p} \right\}^2 = 1.000$$

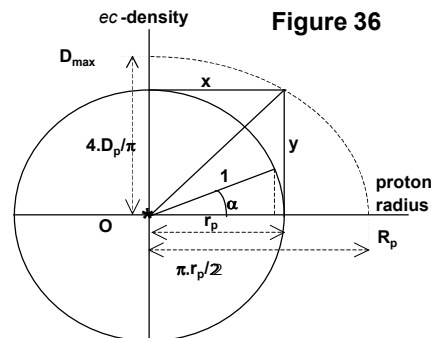

Thus the relation between the distance to the proton centre (r_x) and the *ec*-density along the proton radius (D_y) may be approached by:

$$D_y = \left(\frac{4}{\pi}\right) \cdot D_p \cdot \sqrt{1 - \left(\frac{2 \cdot k_{am} \cdot r_x}{\pi \cdot r_p}\right)^2}$$

D_p = average *ec*-density of the proton (= 3262 fm⁻³)

r_p = average *ec*-distance to the proton centre (= 0.5143 fm)

k_{am} = linear conversion factor for most efficient *ec*-packing (=0.9726)

It is striking that the factor $k_{am} = 0.9726$, needed to reach the value 1, is equal to the value, describing the linear contraction at the recalculation of right-angled *ec*-packing into an oblique-angled one (see also § 5.4.1 and below).

The maximum *ec*-density occurs in the centre (distance zero):

$$D_{max} = \frac{4}{\pi} \cdot D_p = 1.2732 \times \frac{1859}{(4\pi/3) \times (0.5143)^3} = 4154 \text{ fm}^{-3}$$

As the volume of one *ec* is: $(4 \cdot \pi/3) \cdot (6.6979 \times 10^{-3})^3 = 1.2586 \times 10^{-6} \text{ fm}^3$, the amount of 4154 *ec*'s takes a volume of $5.2280 \times 10^{-3} \text{ fm}^3$ (per fm³). Thus, even at the highest density near the proton centre, the *ec*'s take only 0.52% of the available volume.

The minimum *ec*-density, $D_y = 0$, occurs in the periphery of the proton, so that the above equation alters into:

$$r_x = (\pi \cdot r_p) / (2 \cdot k_{am}) = 1.62 \times r_p = R_p = 0.83 \text{ fm} ,$$

which is in agreement with the ep-scattering experiments.

Linear factor of conversion for most efficient *ec*-packing of the nucleonic volume.

There are two ways to fill a given volume completely with lots of smaller volumes. One way is to heap little cubes into the bigger volume. The second way is to do the same

Figure 37

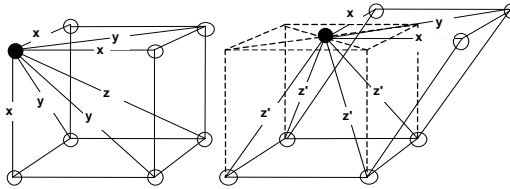

with oblique angled blocs, with volumes equal to those of the cubes, and formed by shoving one of the angular points right into the middle of the former square. As can be seen in **figure 37**, the average distance of that point to the seven others is smaller than the average distance of one

angular point of the cube to the other angular points. If all angular points are equipped with an ec, the respective distances are:

<i>a) cube</i>	<i>b) oblique block</i>
$3 \times (1 - 0.1) \cdot a_m$ (x)	$2 \times (1 - 0.1) \cdot a_m$ (x)
$3 \times (\sqrt{2} - 0.1) \cdot a_m$ (y)	$1 \times (\sqrt{2} - 0.1) \cdot a_m$ (y)
$1 \times (\sqrt{3} - 0.1) \cdot a_m$ (z)	$4 \times (\sqrt{1.5} - 0.1) \cdot a_m$ (z')
average: 1.1821 a_m	average: 1.0876 a_m

The factor 0.1 is related to the ratio $r_e/a_m = 0.1$. The ratio $b/a = 0.92006$, build up by distances into diverse directions, has to be recalculated to a linear sequence:

$$\sqrt[3]{0.92006} = 0.97261$$

This factor will be indicated by k_{am} , thus **$k_{am} = 0.97261$** .

The kinetic energy in nucleons.

The kinetic energy of the nucleonic ec's can be expressed in the idealised proton as the average of the real values. From $m \cdot v^2 = e^2 \cdot k/r$ can be seen, that the kinetic energy is inversely proportionate to the mutual distance between the ec's ($r = a_m$, see § 5.4). As the density is inversely proportionate to r^3 the kinetic energy has to be proportional to the cube root of the ec-density:

$$E_{kin} = f \cdot \sqrt[3]{D_y}$$

In **table 4** and in **figure 38** the values of D_y and $(D_y)^{1/3}$ have been plotted versus a series of distances to the proton centre, using the ellipsoid relation between r_x and D_y and taking the average values of D_p and r_p as a unit. From the table and figure can be seen that not only the series of D_y -values (heavy line) but also the series of $(D_y)^{1/3}$ - values (thin line) have an average of 1 near the mean proton radius.

Table 4

r_x	D_y	$(D_y)^{1/3}$	r_x	D_y	$(D_y)^{1/3}$
0.00	1.2732	1.0839	1.10	0.9323	0.9769
0.10	1.2708	1.0832	1.20	0.8521	0.9481
0.20	1.2634	1.0811	1.30	0.7555	0.9108
0.30	1.2511	1.0775	1.40	0.6348	0.8594
0.40	1.2336	1.0725	1.50	0.4719	0.7786
0.50	1.2107	1.0658	1.60	0.1734	0.5576
0.60	1.1821	1.0574	1.62	0	0
0.70	1.1474	1.0469			
0.80	1.1061	1.0342			
0.90	1.0572	1.0187			
1.00	0.9998	0.9999			
			average	0.999	0.984

This result may provide an indication that the idealised proton contains average values

of energy density as well. It supports the idea, that the homogeneous ec-model of nucleons may be used for the quantitative deductions, as has been done in the underlying study, without causing a change in the results.

5.5 The average relative velocity of proton charges

In § 5.2 we have found a value for this velocity, using the formula

$$\mathbf{V}_p = \left[\{r_p - (2/\pi)^2 \cdot a_{mp} - 2e_{ex}\} / r_p \right] \times 0.7844645 \times c = 0.73991 \cdot c,$$

in which $a_{mp} = 0.1311 \cdot r_p$ and $e_{ex} = 1.8311 \times 10^{-3} \cdot r_p$ (see § 5.4.2 and § 3.5.3).

It can be proved now that a second approach is possible, using the ratio of values for energy equilibrium in neutrons and protons, PE_n and PE_p respectively:

$$\frac{-PE_n}{-PE_p} = \frac{(1862/4) \cdot m_e \cdot \left\{ (2/\pi)^2 V_N \right\}^2}{(1859/4) \cdot m_e \cdot \left\{ (2/\pi)^2 V_p \right\}^2} = \frac{1862 \cdot V_N^2}{1859 \cdot V_p^2}, \text{ hence } \frac{V_N}{V_p} = \sqrt{\frac{1859 \cdot PE_n}{1862 \cdot PE_p}}$$

By substitution of the values:

$$V_N = 0.7413 \cdot c, \quad PE_n = -3.44005 \times 10^{-12} \text{ J (}\S 5.4.2) \text{ and}$$

$$PE_p = PE_n - E_a = -3.4217 \times 10^{-12} \text{ J (}\S 5.4.1), \text{ the value of } V_p \text{ can be found:}$$

$$\mathbf{V}_p = 0.7399 \cdot c, \text{ which is equal to the value of the first approach.}$$

5.6 The misunderstanding of the ec-radius.

The classical radius of the elementary charges is given by: $r_e^* = e^2 / (4\pi\epsilon_0 \cdot m_e \cdot c^2)$, or by $r_e^* = \alpha \hbar / (m_e \cdot c) = 2.8179 \times 10^{-15} \text{ m}$. However, the charge e says nothing about its spin, though in the second equation α and \hbar point to rotation.

It is revealing that in § 3.5.5 the smallest distance between two free and opposite ec's was found to be: $r_m = 5.4097 \times 10^{-15} \text{ m}$, which is the diameter of the stable, rotating, structure as a result of the so-called annihilation.

The radius of that system $r_m/2 = 2.7049 \times 10^{-15} \text{ m}$ is close to r_e^* .

The radius of $r_e = 6.6979 \times 10^{-18} \text{ m}$, found in § 5.1 - 5.4 by implicating the radius of the proton in the calculation, does not possess the above disadvantage, so it may be seen as the real ec-radius.

Fig.38. Density and energy of ec's versus proton radius

